

Polarizing–alignment layers for twisted nematic cells

TATIANA SERGAN

Liquid Crystal Institute, Kent State University, Kent, OH 44242, USA

TOD SCHNEIDER

Chemical Physics Interdisciplinary Program, Kent State University, Kent,
OH 44242, USA

JACK KELLY*

Liquid Crystal Institute, Kent State University, Kent, OH 44242, USA

and O. D. LAVRETOVICH

Liquid Crystal Institute, Kent State University, Kent, OH 44242, USA

(Received 28 July 1999; accepted 11 November 1999)

We describe polarizing films formed from the lyotropic liquid crystalline phases of dyes dissolved in water. The dye polarizers possess a high dichroic ratio close to that of conventional polarizers. In addition, the dried dye films provide a uniform homogeneous orientation for thermotropic nematic materials. Therefore, thin dye films can simultaneously serve as internal polarizers and as alignment agents. These properties make them especially suitable for twisted nematic devices based on low cost birefringent plastic substrates.

1. Introduction

There are several types of high dichroic ratio polarizers possessing sufficient optical performance, which are used for various liquid crystal applications. The most commonly used are iodine polarizers that are composed of a thin polyvinyl alcohol (PVA) film containing elongated iodine complexes [1]. Another type is a dyestuff polarizer containing long flat molecules of dichroic dyes [2]. Both types of polarizers require a high molecular order for the absorbing material. This order is achieved by the adsorption of the dye onto a stretched film of PVA. Preferential orientation of the PVA polymer chains along the stretching direction provides a highly anisotropic matrix that produces this ordering and concomitant optical anisotropy. The process of incorporating the dye molecules into the PVA matrix can involve special dye treatments including absorption from liquid crystalline lyotropic phases in various solvents [3]. These dichroic polarizers are typically based on dichroic materials with a rod-like molecular or crystalline structure whose long molecular or crystal axis is almost parallel to the transition moment of the light absorption. Such polarizers

absorb light polarized along the long molecular axis and transmit most of the light polarized in all directions orthogonal to this axis. Thus, these polarizers have one absorption axis and two transmission axes. The typical transmission of a crossed pair of iodine polarizers is about 0.06% at normal light incidence.

Two films of triacetyl cellulose (TAC) usually protect the polarizing layer. The TAC layers exhibit a small birefringence of 5 to 10 nm in the plane of the film and a higher negative out-of-plane birefringence of -50 to -70 nm [1]. The out-of-plane birefringence of the TAC film causes light leakage at wide viewing angles when two dichroic polarizers are crossed. Thus, the transmittance of a typical pair of crossed dichroic polarizers reaches 3% at oblique angles of up to 60° [1].

Dichroic polarizers are used in liquid crystal displays as external polarizers for liquid crystal shutters. Liquid crystal cells are usually assembled with glass substrates; however, the modern market demands inexpensive, lightweight and 'unbreakable' display units made with plastic parts. The market for plastic displays is very large, but the advantages of plastic are offset by the low optical quality of the currently available plastic substrates. Most of the low cost and easy-to-manufacture plastic substrates, such as those using poly(ethylene terephthalate)

* Author for correspondence;
e-mail: jkelly@scorpio.kent.edu

(PET), that are compatible with display processing are highly birefringent. This is a serious shortcoming for plastic displays with external polarizers, as the birefringence of plastics placed between the polarizers causes a tremendous light leakage and degrades the readability of the display. This effect could be overcome by using *internal* polarizers that would leave the birefringent plastic outside the polarizing layer.

In this work, we studied the function and application of dye films that simultaneously serve as internal polarizers and as alignment agents to create a planar orientation for thermotropic liquid crystal materials. This double feature allows us to build a high performance twisted nematic (TN) display with plastic substrates outside the polarizing and active layers. Such polarizers can also eliminate parallax problems that plague reflective displays using external polarizers.

2. Optical performance of the dye polarizers

The polarizers studied in our work were composed of thin dye films made from an aqueous solution of dyes manufactured by Optiva™ Inc.† The mixture was colour balanced to be achromatic in the spectral range 450 to

†Detailed information can be found at URL: <http://www.optivainc.com/>

800 nm. The dye molecules are plank-like with a poly-aromatic rigid core and have a hydrophilic ionic group at the periphery to enhance solubility. At concentrations above 5 wt %, their aqueous solutions form a nematic phase (referred to as a chromonic nematic liquid crystal [4]). Orientation of the film was produced by shear flow alignment of the nematic mixture [5] using a 1/4 inch wire-wound wet-film applicator rod (No. 3 and No. 6, Paul N. Gardner Co., Inc.). Upon drying, we found that the transmission axis of the polarizing film coincides with the shearing direction. The light transmission of the polarizer was controlled by the selection of wire thickness on the wet-film applicator and the concentration of the dye in aqueous solution—higher concentration implies more absorption of light. The dried dye film was typically thinner than 1 μm .

To compare the optical performance of these dye polarizers with conventional dichroic polarizers, we used TAC films for substrates. All the optical measurements described in this section were performed with TAC layers stacked inside the absorbing dye layers. This allows us to make a more direct comparison of optical performance with the commercially available dichroic polarizers.

We studied the spectral transmittance of the dye films using a Perkin-Elmer Lambda 18 spectrometer. Figure 1 shows the transmission spectra of the dye film with transmission axis parallel and perpendicular to the polarized

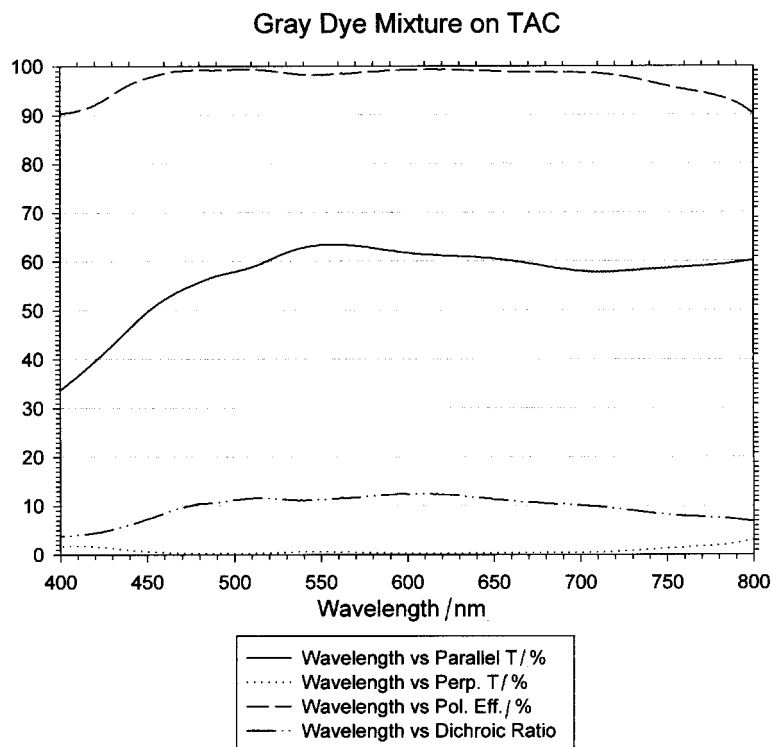

Figure 1. Transmission spectra of the dye polarizers, as measured by a Perkin-Elmer Lambda 18 spectrometer.

light within the spectrometer. The dye polarizers provide nearly uniform absorption within the visible spectral region. The polarization efficiency of thicker dye films was up to 99% with a dichroic ratio [6] of up to 12.

The transmission of crossed dye polarizing films at different viewing directions can be seen in figure 2. The curves on the polar plot are isoluminance transmission curves that were normalized to the incident light intensity. Each viewing direction is characterized by polar and azimuthal angles. On the contour plot, the radius corresponds to the polar viewing angle whereas the polar angle corresponds to the azimuthal viewing angle. Crossed polarizers have very low transmission (0.1 ~ 0.2%) at wide viewing angles compared with conventional dichroic polarizers (3%) [1]. The minimum transmission (~0.1%) occurs at an oblique direction in contrast to the behaviour of conventional polarizers, which have a peak absorption at normal incidence. This optical behaviour suggests that, unlike conventional polarizers, these dye films have one transmission direction along the shearing direction and absorb light polarized in all directions perpendicular to the transmission axis. This presumption was confirmed by polarizer modelling using the 4X4-propagation matrix method developed by Berreman [7]. Two crossed 2 μm films, with absorption coefficients $k_e = 0.001 \sim 0.01$ along the transmission axis in the plane of the film and $k_o = 0.07 \sim 0.14$ in the two directions perpendicular to the transmission axis, were modelled in the wavelength range 400 to 800 nm.

The modelled films featured a high absorption at wide viewing angles and reproduced the results of the experiment (see figure 3).

We can understand the absorption features more clearly by examining the supramolecular structure. As was pointed out earlier, the dye molecules are relatively flat and plank-like with a polyaromatic core that is responsible for light absorption. Light polarized in the plane of the molecule is mostly absorbed whereas light polarized perpendicular to the plane of the molecule is mostly transmitted. Since the transmission axis is in the plane of the film, the molecules should be standing on their edges as seen in figure 4.

3. Optical performance of a TN cell with dye polarizing–alignment layers

Studies of dye coatings under the polarizing microscope revealed that they are uniform and feature a preferred axis along the shearing direction. This suggests the use of the dye film as an alignment layer for rod-like thermotropic liquid crystals. We built a twisted nematic cell using PET plastic substrates with pre-deposited thin indium tin oxide (ITO) conducting layers. To provide more uniformity in dye wetting and alignment, we spin-coated and then rubbed a polyimide over the ITO layer. The polyimide compound used for the intermediate layer was chemically modified to provide low temperature processing that was suitable for polymer substrates. The dye polarizing–alignment layer was sheared over the polyimide layer. The polarizing dye film provides a uniform planar alignment of liquid

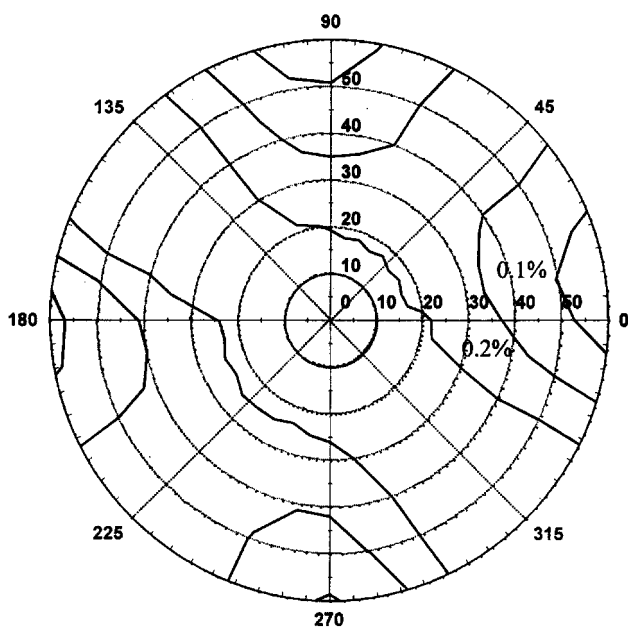

Figure 2. Measured contour plot of the % of white light transmitted through crossed dye polarizers. The radius and azimuthal angle of the plot correspond to the polar and azimuthal viewing angles, respectively.

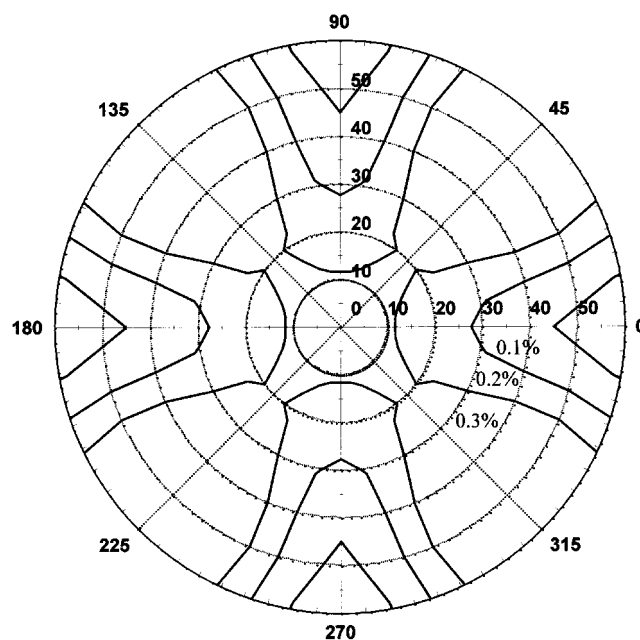

Figure 3. Modelled contour plot of the % of white light transmitted through two crossed dye polarizers.

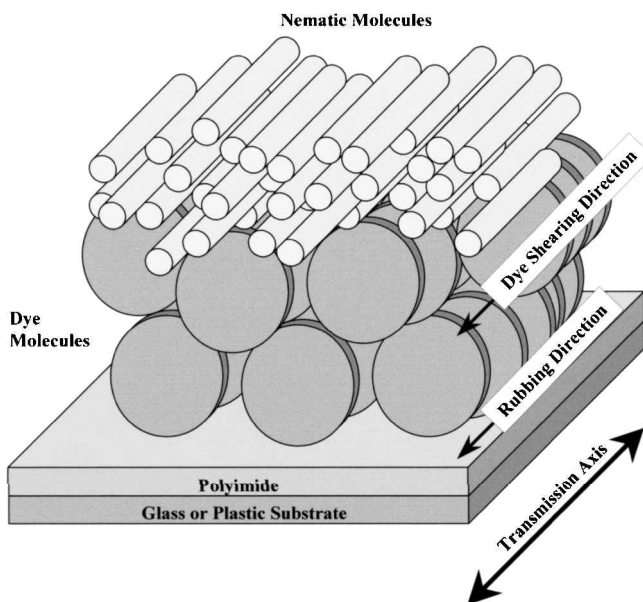

Figure 4. Alignment of nematic molecules on a dye layer; disks schematically represent the dye molecules.

crystal mixtures based on 4-*n*-pentyl-4'-cyanobiphenyl (5CB), e.g. a ZLI 4792 mixture by EM Industries. The director of the liquid crystal is aligned along the shearing direction (transmission axis) of the dye layer as seen in figure 4. A schematic diagram of the display is shown in figure 5. To make the TN device, the shearing directions of the dye layers were crossed. Glass spacers of 5 μm controlled the cell gap. The cell was filled with a mixture of ZLI 4792 and 0.1 wt % of chiral dopant CB15 by

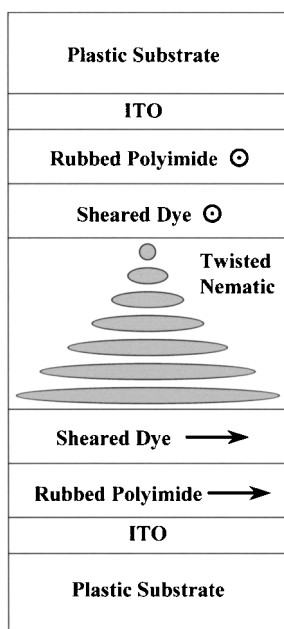

Figure 5. A schematic diagram of the plastic TN display.

EM Industries. The chiral dopant stabilized a right-handed twist of the mixture. The device as constructed, operates in a normally white mode—that is, transmitting light when no voltage is applied to it. The cell, as constructed, satisfied the conditions of the first Gooch–Terry minimum [8].

Figure 6 shows the texture of the plastic TN display in the bright state. Figure 7 shows the texture of the TN cell when a 6 V a.c. square wave was applied at a 1 kHz frequency. The display appears black in this state, as the liquid crystal molecules are nearly homeotropic in orientation. The light leakage of this extinguished state is determined by the quality of crossed polarizers and the liquid crystal structure. The head-on light transmission is close to that of crossed polarizers, as a small percentage of the light is scattered or absorbed by the liquid crystal. The plastic substrates have no impact on the transmittance of the cell in the extinguished state. However, one can observe inversion walls separating two reverse tilt domains. The dual domain structure for this dark state is probably due to the low (possibly zero) pretilt angle yielded by the alignment layer. Figure 8 shows an isocontrast plot for the plastic display driven between 0 and 6 V. The display features a symmetric viewing cone similar to a dual domain TN cell [9]. The origin of this behaviour is two-fold. First, there is a low

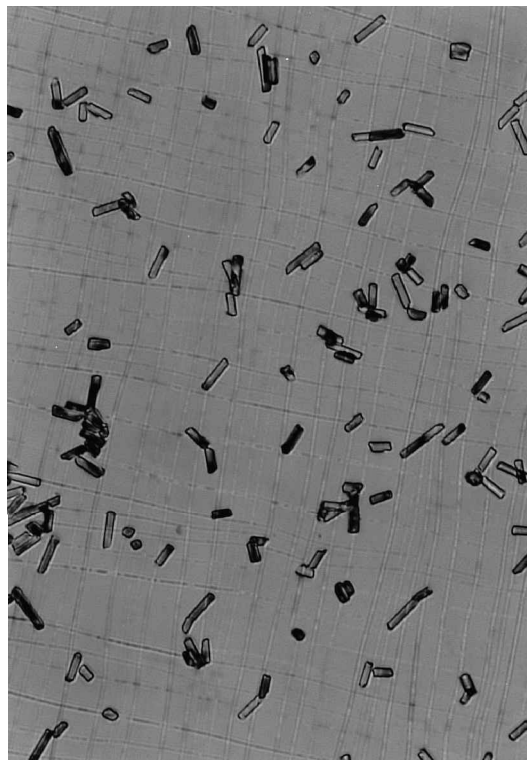

Figure 6. Photomicrograph of a TN cell with dye polarizing-alignment layers while no voltage is applied; it has a uniform twisted structure.



Figure 7. Photomicrograph of a TN cell with dye polarizing–alignment layers while 6 V is applied; note the dual domain structure.

technique. The contrast ratio for head-on viewing is as high as 70:1. Modelling of a display with dye polarizers featuring the optical characteristics described in § 2 yields a head-on contrast ratio of 110:1, which is fairly close to that of the device built. Thus, we built a TN display with plastic substrates and internal polarizers avoiding the undesired birefringence of plastic.

To make the plastic TN display more rigid and stable under different environmental conditions, we stabilized it with polymer walls using the technique of field-induced polymer phase separation [10]. To accomplish this, the liquid crystal mixture was doped with 8–10% of photocurable Norland optical adhesive N81, which is soluble in the liquid crystal. To create a network of polymer walls, we used plastic substrates with patterned electrodes that were covered with dye polarizing–alignment layers. Phase separation of the liquid crystal and optical adhesive occurred at room temperature when a voltage of 60 V was applied to the assembled TN cell. Under the electric field, the monomer collected in the low field regions between the electrodes. The separated mixture was subsequently cured with unpolarized UV light. Hence, we were able to create a network of polymer walls to stabilize the plastic TN display. Figure 9 shows the cell stabilized with polymer walls at 0 V. The space within a pixel appears bright because of the rotation of light polarization by the TN structure. However, the isotropic

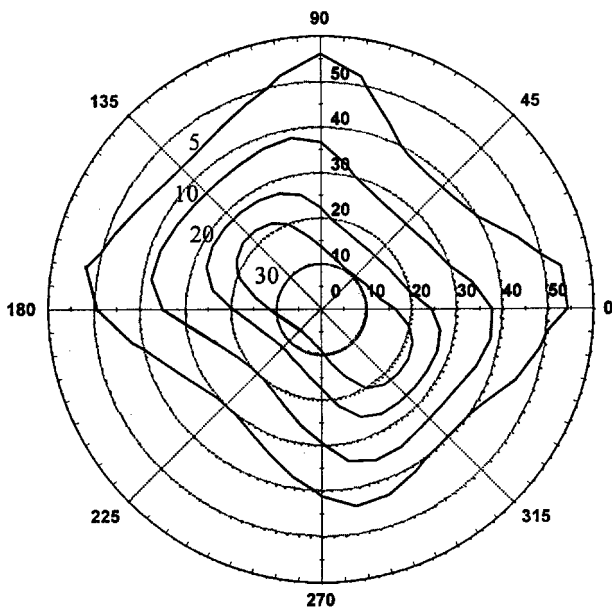

Figure 8. An isocontrast plot for the plastic TN display with dye polarizing–alignment layers driven between 0 and 6 V.

pretilt angle of the alignment layer providing a reverse-tilt dual-domain structure; second, there is an averaging due to small deviations of the shearing direction (transmission axis) that results from the dye deposition

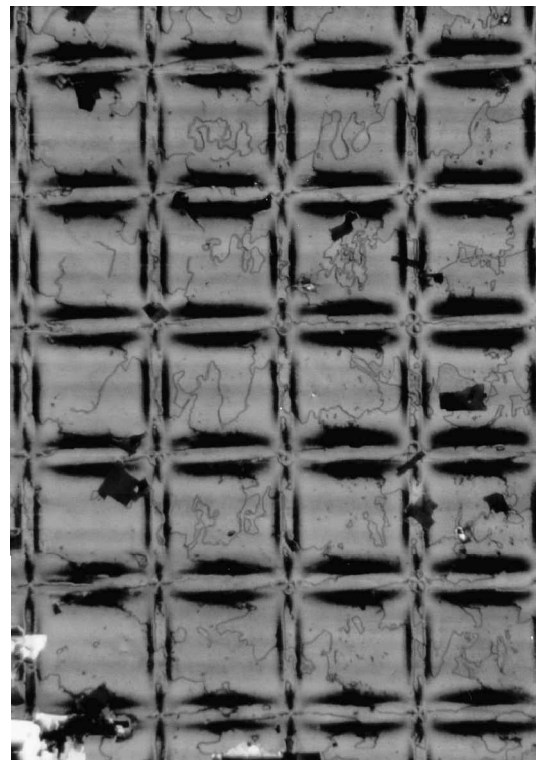

Figure 9. Photomicrograph of polymer walls in the plastic TN display.

walls appear dark exhibiting the low transmission of crossed polarizers. Further work needs to be done in order to improve the optical performance of the polymer stabilized TN display.

4. Conclusions

We have studied the optical performance of aqueous dye solutions sheared on polymer substrates. After cessation of shear the dye dries, preserving order in the shearing direction. The dye film has the transmission axis along the shearing direction and absorbs light polarized in the plane orthogonal to the shearing direction. Through adjustments of the dye composition and deposition conditions, we achieved a crossed polarizer transmittance of 0.1–0.3% at wide viewing angles while retaining a high polarization efficiency. In addition, we found that the dye films can provide uniform planar alignment for rod-like thermotropic liquid crystal materials. They can simultaneously serve as *internal* polarizers and alignment layers in plastic TN displays. The use of internal polarizers permits the use of low optical quality but easy-to-process inexpensive plastic substrates for TN displays. We have demonstrated that TN displays with dye polarizing–alignment layers can provide reasonably high head-on contrast ratios of at least 70:1 while achieving viewing angle characteristics similar to those of a reverse tilt dual domain TN cell. Finally, a network of polymer walls can be used to stabilize the plastic display.

This research was supported by the National Science Foundation Science and Technology Center for Advanced Liquid Crystalline Optical Materials (ALCOM) under contract N. DMR 89-20147 and a grant from the 3M company, N. GI01343. We would like to thank Prof. L. C. Chien for providing the polyimide and Prof. J. West with his colleagues Y. Kim and H. Wonderly for the polymer wall technology, polymer display manufacturing, and samples of plastic substrates with patterned electrodes. We would especially like to thank P. Lazarev and T. Gardner for helpful discussions.

References

- [1] HERKE, R., JAMAL, S. H., and KELLY, J. R., 1995, *J. SID*, **3/1**, 9.
- [2] HAYASHI, N., OGINO, K., KURATA, N., and FUJITA, F., 1998, *SID Digest*, **29**, 47.
- [3] DREYER, J. F., 1949, USP 2 481 830.
- [4] LYDON, J., 1998, *Curr. Opin. colloid interface Sci.*, **3**, 458.
- [5] SCHMIDT, G., MÜLLER, S., LIDNER, P., SCHMIDT, C., and RICHTERING, W., 1998, *J. phys. Chem. B*, **102**, 507.
- [6] DIRIX, Y., TERVOORT, T. A., and BASTIAANSEN, C., 1995, *Macromolecules*, **28**, 486.
- [7] BERREMAN, D. W., 1972, *J. opt. Soc. Am.*, **62**, 502.
- [8] GOOCH, C. H., and TERRY, H. A., 1975, *J. Phys. D: appl. Phys.*, **8**, 1575.
- [9] JAMAL, S. H., KELLY, J. R., and WEST, J. L., 1995, *Jpn. J. appl. Phys.*, **34**, L1368.
- [10] KIM, Y., FRANCL, J., TAHERI, B., and WEST, J. L., 1998, *Appl. Phys. Lett.*, **72**, 2253.